

5005

Female barb connector BSPT thread

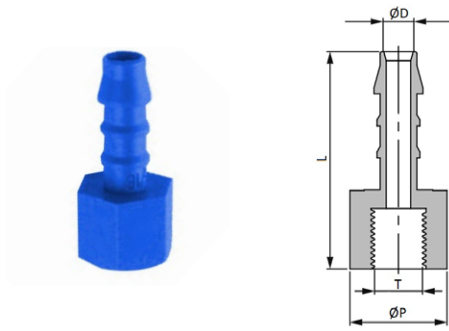

CODE	T	ØD	ØP	L	GR.
5005TR185	R1/8"	5	14	34,4	2,0
5005TR145	R1/4"	5	17	35,2	2,7
5005TR385	R3/8"	5	22	36,5	4,57
5005TR125	R1/2"	5	26	38,7	6,6
5005TR186	R1/8"	6	14	36,3	2,15
5005TR146	R1/4"	6	17	37,2	2,9
5005TR386	R3/8"	6	22	38,3	4,8
5005TR126	R1/2"	6	26	40,8	7,0
5005TR188	R1/8"	8	14	39,4	2,5
5005TR388	R3/8"	8	22	40,4	5,0
5005TR128	R1/2"	8	26	42,7	7,1
5005TR1410	R1/4"	10	17	41,5	3,6
5005TR3810	R3/8"	10	22	42,3	5,4
5005TR1210	R1/2"	10	26	45,0	7,5
5005TR1412	R1/4"	12	17	42,4	4,1
5005TR3812	R3/8"	12	22	43,3	6,2
5005TR1212	R1/2"	12	26	46,0	8,0
5005TR3814	R3/8"	14	22	45,0	6,9
5005TR1214	R1/2"	14	26	47,3	8,7
5005TR1216	R1/2"	16	26	48,1	9,0
5005TR1219	R1/2"	19	26	48,8	9,5

5010

Male barb connector BSPT thread

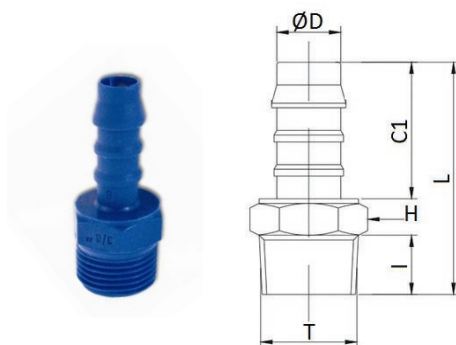

CODE	T	ØD	I	C1	L	H	GR.
5010TR184	R1/8"	4	8,0	16,0	30,5	11	1,0
5010TR144	R1/4"	4	10,0	16,0	33,5	14	1,2
5010TR185	R1/8"	5	8,0	21,0	35,5	11	1,0
5010TR145	R1/4"	5	10,0	21,0	38,5	14	1,0
5010TR125	R1/2"	5	10,0	21,0	41,4	22	1,0
5010TR186	R1/8"	6	8,0	23,0	37,5	11	1,0
5010TR146	R1/4"	6	10,0	23,0	40,5	14	2,0
5010TR386	R3/8"	6	10,0	23,0	40,5	17	3,0
5010TR126	R1/2"	6	12,5	23,0	44,0	22	6,0
5010TR346	R3/4"	6	14,5	23,0	46,0	22	8,2
5010TR188	R1/8"	8	8,0	25,0	39,5	11	2,0
5010TR148	R1/4"	8	10,0	25,0	42,5	14	2,0
5010TR388	R3/8"	8	10,0	25,0	42,5	17	3,0
5010TR128	R1/2"	8	12,5	25,0	46,0	22	6,0
5010TR348	R3/4"	8	12,5	25,0	47,1	27	6,0
5010TR1410	R1/4"	10	10,0	27,0	44,0	14	1,0
5010TR3810	R3/8"	10	10,0	27,0	44,0	17	4,0
5010TR1210	R1/2"	10	12,5	27,0	48,0	22	6,0
5010TR3410	R3/4"	10	14,5	27,0	50,0	27	9,1
5010TR1412	R1/4"	12	10,0	28,0	45,0	14	4,0
5010TR3812	R3/4"	12	10,0	28,0	45,0	17	4,0
5010TR1212	R1/2"	12	12,5	28,0	49,0	22	7,0
5010TR3412	R3/4"	12	14,5	28,0	51,0	27	9,2
5010TR3814	R3/8"	14	10,0	29,5	47,0	17	6,0
5010TR1214	R1/2"	14	12,5	29,5	50,5	22	7,0
5010TR3414	R3/4"	14	14,5	29,5	52,5	27	9,8
5010TR1216	R1/2"	16	12,5	30,0	51,0	22	8,0
5010TR3416	R3/4"	16	14,5	30,0	53,0	27	10,0
5010TR1219	R1/2"	19	12,5	31,0	52,0	22	9,0
5010TR3419	R3/4"	19	14,5	31,0	54,0	27	15,0
5010TR119	R1"	19	21,0	31,0	62,0	27	18,8

